



2015 VERSION
1.7
© TechnoKom

TKLS
AutoGRAPH

FUEL LEVEL SENSOR

USER MANUAL



Table of Contents

Introduction	3
Product Overview	3
Software Copyright Notice	4
Safe Operation and Installation	4
Technical Specification	5
Scope of Supply	6
Components of Sensor	7
Interface Connectors	8
Interface Connectors	9
Connection of the Sensor	12
Power Supply Connection	13
RS-485 (TIA/EIA-485-A) Bus Connection	14
Frequency Output Connection	15
Error Codes	16
Sensor Configuration	17
Driver Installation	18
Modbus Register Mapping	19
Appendix	20

Introduction

This User Manual applies to the TKLS fuel level sensor (hereafter – TKLS, sensor) produced by TechnoKom Ltd. It contains installation and connection procedures of the TKLS, as well as its function and control.

This Manual is intended for specialists who are aware of the maintenance and installation principles typical for motor vehicles and are proficient in using the electronic and electrical equipment of various vehicles.

To ensure the best performance of the TKLS, it should be installed and set up only by qualified specialists.

The TKLS sensor can operate both as a part of a fuel monitoring system and as a part of a fleet management system. For proper operation of the TKLS sensor, the customer should be aware of the operating principles of these systems as a whole, as well as understanding the functions of its individual components



All information on functions, functional capabilities and other specifications related to TKLS fuel level sensors, as well as all information contained in this User Manual is based on current data (at time of writing) and is deemed to be valid as of the date of publication.

TechnoKom reserves the right to modify the information or specifications without prior notice or commitment.

Product Overview

The TKLS fuel level sensor is designed to measure fuel level in a vehicle fuel tank and transfer this information to external devices via one of the supported interfaces. The TKLS can be used as a replacement of the factory-fitted standard fuel level sensor or as an additional sensor for fuel level monitoring.

The TKLS supports data transfer via RS-485 bus, in LLS and Modbus protocols, and via frequency output as pulses proportional to measured fuel level, PWM signal or periodic sequence.

In addition to fuel level, the sensor measures ambient temperature and sends the readings to an external device.

Any device equipped with RS-485 which supports data exchange in LLS or Modbus protocols can operate as an external device (for example, a level indicator or an onboard vehicle tracking device).

Software Copyright Notice

Products of TechnoKom referred to in this Manual may incorporate software stored in semiconductor memory or other media, copyrights to which belong to TechnoKom or third parties. Laws of the Russian Federation and other countries secure certain exclusive rights of TechnoKom and third parties to the software, which is subjected to copyright, for example, exclusive rights for distribution or reproduction.

Therefore, any alteration, reverse engineering, distribution or reproduction of any software incorporated in TechnoKom products, is prohibited to the extent provided by law. Furthermore, purchase of TechnoKom products does not imply direct, indirect or other granting of any licenses related to copyrights, patents and patent applications of TechnoKom or any third party, except for an ordinary, nonexclusive free license for use, which is granted in virtue of law upon each sale of the product.

The communication protocol between the AutoGRAPH Series on-board vehicle tracking controllers and the TKLS fuel level sensors (AutoGRAPH Hardware Interface Protocol) is considered to be confidential information and intellectual property of TechnoKom. The AutoGRAPH Hardware Interface Protocol (AGHIP) shall be transferred by TechnoKom to integrators and software manufacturers only upon signing a Confidentiality Undertaking. Unauthorized distribution of the AutoGRAPH Hardware Interface Protocol is strictly prohibited.

Safe Operation and Installation

This section contains important information for effective and safe operation of TKLS fuel level sensors. Please read the information below before using the sensor.

- Sensors with damaged insulation of conductive parts, testing probe and body must not be used.
- Operational conditions of the TKLS such as electrical and environmental characteristics and condition of measured liquid should fit the requirements contained in this User Manual. Otherwise, the manufacturer will not be responsible for sensor safety and functional efficiency.
- All connections should be made when the sensor and external devices to be connected to the sensor are disconnected from the power supply.

Technical Specification

Description	Value
Output Interface	RS-485 (TIA/EIA-485-A), Frequency output
Protocols for RS-485	AGHIP / LLS / ModBus
Bluetooth (BLE)	Yes
Built-in Accelerometer / Inclinator	Yes
Self-diagnostic	Yes
Error Report	Yes
Remote Configuration via Bluetooth	Yes
Remote Configuration via RS-485	Yes
Remote Firmware Update	Yes
Logging	Yes
Temperature Measuring*	Yes
Digital Input, numbers	1
Frequency Output	
Output Frequency Range, Hz	100...3000
Output Type	Open collector
Maximum Load Current, mA	200
Measuring Features	
Operational Liquids	Gasoline, fuel oil
Level Measuring Accuracy, %	≤1
Resolution, bit	12
Temperature Measuring Range, °C	-40...+85
Temperature Measuring Accuracy, °C	±1
Operational Conditions	
Operational Voltage, V	+7...+60
Power Consumption at 12 VDC, mA	< 30
Operational Temperature, °C	-40...+85
Protection Class	IP69K
Probe Length, mm	750 / 1000 / 1500 / 2000
Mounting	SAE 5-bolt pattern
Average Life Time, years	10

*The function is available only when connecting the TKLS to the AutoGRAPH on-board controller. To read temperature readings from the TKLS, the "Wide record" option should be enabled in the controller's settings.

Scope of Supply

No	Description	Qty
1	"TKLS" Fuel Level Sensor with Plastic Cover	1 pc.
2	Mounting Kit*	1 set
3	Signal Cable in Corrugated Pipe	7,5 m
3	Registration Certificate	1 pc.
4	Warranty Certificate	1 pc.

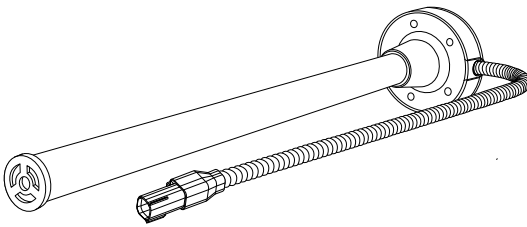

1

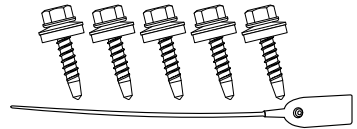

2

**The mounting kit includes following tools:

Seal gasket	- 1 pc.
Self-tapping screws with mounted washer and sealing, M5 size	- 5 pc.
Rivet nut, knurled, M5 size	- 5 pc.
Machine screw, M5 size	- 5 pc.
Plastic seal	- 1 pc.
Meter seal (for connector)	- 1 pc.
End cap (spare)	- 1 pc.
Fuse with holder	- 1 pc.

Components of Sensor

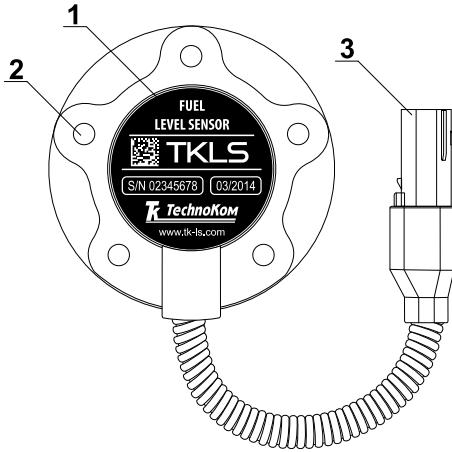

1. **Product identification*.**
2. **Mounting hole (x5).**
3. **Interface Connector 1 (male).**
4. **Sensor cover.**
5. **Seal gasket.**
6. **Measuring probe.**
7. **End cap**.**
8. **Sealing hole (x4).**

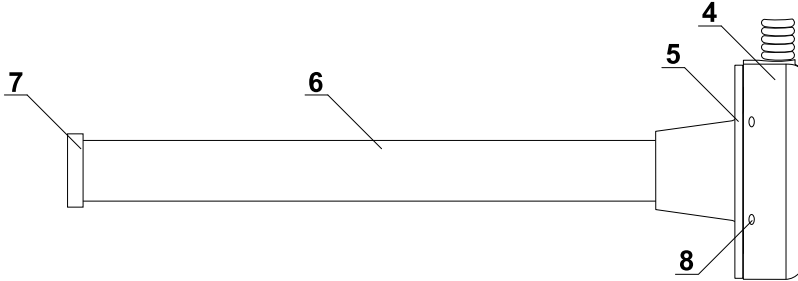

*Device designation contains trademark and contact details of the manufacturer, device description, serial number and release date of the device.

**The sensor is supplied with a transport plug, which should be removed before sensor installation.

Interface Connectors

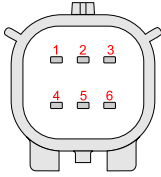

Interface Connector 1 (male)

View from side of pins

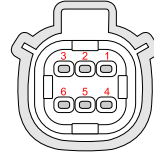

Connector 2 (female)

View from side of sockets

No	Wire Colour	Assignment
1	Red	+Vin
2	Orange	RS-485 (A)
3	Gray	Frequency output (OK)
4	Black	-Vin
5	Brown	RS-485 (B)
6	White	Digital input (active low)

Both connectors are keyed to prevent wrong orientation.

Interface Connectors

Before installation it is highly recommended to check the sensor for any mechanical damage.

Sensor location

- The sensor location depends on the geometric form of the tank and should be chosen in such a way as to provide accurate readings regardless of fuel movement in the tank during vehicle motion.
- Normally, the sensor should be located at the centre of the top of the tank. See figures below:

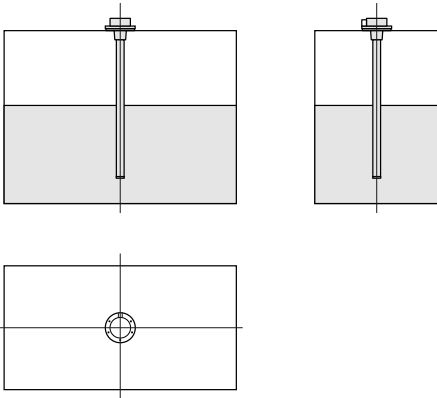

- If it is impossible to install the sensor as shown above, it should be located as close as possible to the recommended area.
- If, due to the geometric features of the tank, one fuel level sensor does not provide the required accuracy of readings, it is recommended that several sensors are installed into the tank. A set of two sensors is commonly used in this way. In this case, the fuel level in the tank amounts to the average readings of the two sensors.

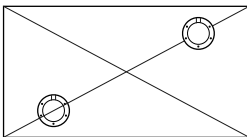

Preparation of the fuel tank

All preparation work must be performed in accordance with the safety requirements specified for the tank:

- Before installation on a petrol tank, it must be completely emptied of petrol and filled with water.
- Before drilling, ensure that there aren't any baffle plates inside in the tank in the proposed

sensor installation area within a radius of 20 mm. This can be checked by drilling a small hole (about 3 mm) in the installation area.

- Drill a central hole 35...37 mm diameter using a bimetal boring bit.
- Drill five holes for SAE-5 bolts.
- Install the seal gasket on the sensor, then mount the sensor into the tank.

Sensor cutting

- The sensor length can be cut to match the specific fuel tank. To do this, you should follow these steps:
 - Measure the tank depth by inserting a ruler in the tank through the central hole that has been prepared for installing the sensor.
 - Measure the tank depth on the effective length of the sensor L . It is recommended that the sensor is shorter than the tank depth by 10-30 mm to prevent false reading due to impurities (including water) in the bottom of the tank. The effective length of the sensor should be adjusted depending on the amount of the impurities.
 - When cutting the sensor, be sure that the cut is straight and perpendicular to the roll axis of the sensor.

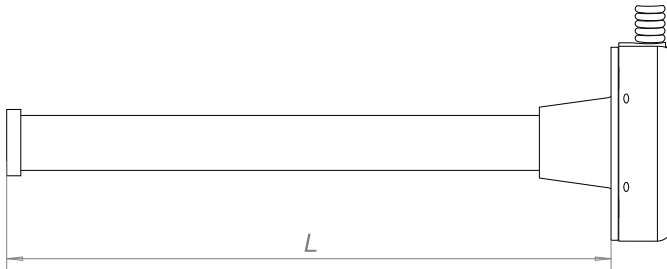

- After cutting, install the supplied end cap on the measuring probe (see figure below). Do not forget to remove the transport plug before the sensor installation.

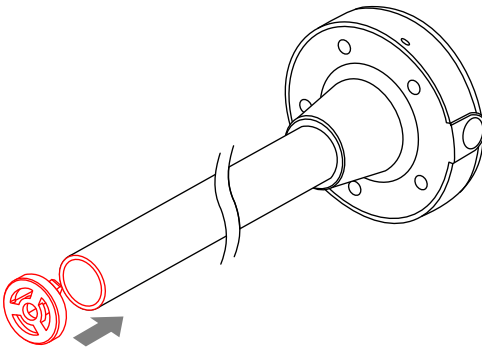



The effective length of the sensor must be at least 150 mm after cutting.

Sensor installation

- Install the seal gasket on the sensor with the wide side of the seal's outer ring facing the sensor (see figure below). When installing the seal, also be sure that the mounting holes of the sensor matches the mounting holes of the seal.

TO SENSOR

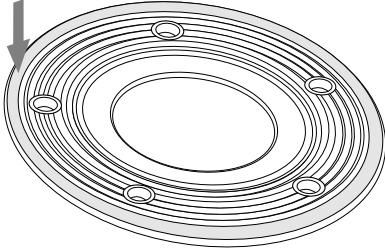

TO FUEL TANK

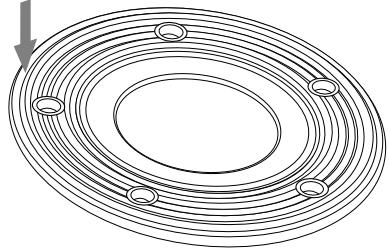

- Install the sensor into the tank and tighten five fastening screws supplied with the sensor.

Connection of the Sensor

This section covers connection procedures of the TKLS fuel level sensor:

- Power supply connection
- RS-485 bus connection
- Frequency output connection

The sensor is supplied with a 7.5m signal cable in a corrugated pipe. The cable is equipped with a female connector (Connector 2) for connecting to the sensor (to Connector 1). Both connectors are keyed, which prevents incorrect orientation.

When making connections, pay careful attention to the safety rules stipulated by the regulations for motor vehicle repair procedures. All connections should be properly isolated and securely connected. If the wire is too short, it can be spliced with a wire of at least 0.5 mm² cross section (20 AWG or thicker).

The TKLS sensor can be connected to any external unit that supports ModBus or LLS protocols to transfer fuel level readings.

The TKLS sensor is equipped with a frequency output that provides transfer of fuel level values in the form of pulses at a variable frequency. The sensor is also capable of measuring ambient temperature.



All connections should be performed when the sensor and all external devices be connected to the sensor are disconnected from the power supply.

Power Supply Connection

When making the power connection, pay careful attention to the safety rules stipulated by the regulations for motor vehicle repair procedures.

The sensor is supplied with a fuse intended to provide short circuit protection of the power supply. The fuse holder is installed on a wire ring, which should be cut before operation.

The power supply input of the sensor is rated for a voltage of 7-60 V.

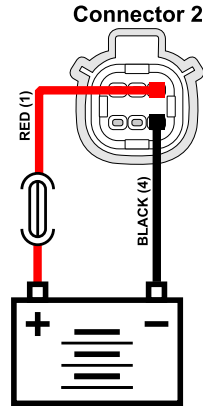

To connect the power to the sensor you should follow these steps:

- Connect “+Vin” wire of the signal cable to “+Vin” line of vehicle power system and connect “-Vin” wire to “-Vin” line of the vehicle power system.
- Connect the fuse supplied with the sensor to the “+Vin” line. The fuse should be placed as close as possible to the point where the TKLS is connected to vehicle power system.
- Connect Connector 2 of the signal cable to the male Connector 1.

RS-485 (TIA/EIA-485-A) Bus Connection

The TKLS sensor is equipped with an RS-485 (TIA/EIA-485-A) bus, which allows the sensor to transfer collected data to an external unit equipped with RS-485. The TKLS supports the following commonly used data transmission protocols: LLS and ModBus. The data transfer protocol can be selected using the configuration program. The configuration program ("TKLSConf") can be downloaded for free from the manufacturer's official web site (www.tk-chel.ru).

General diagram of connection of external devices to RS-485 bus:

The connection diagram of the TKLS to the AutoGRAPH-GSM on-board vehicle tracking controller is depicted in the figure below. This diagram is also true for another AutoGRAPH Series on-board vehicle tracking controllers and other devices which are connected to the sensor via the RS-485 bus.

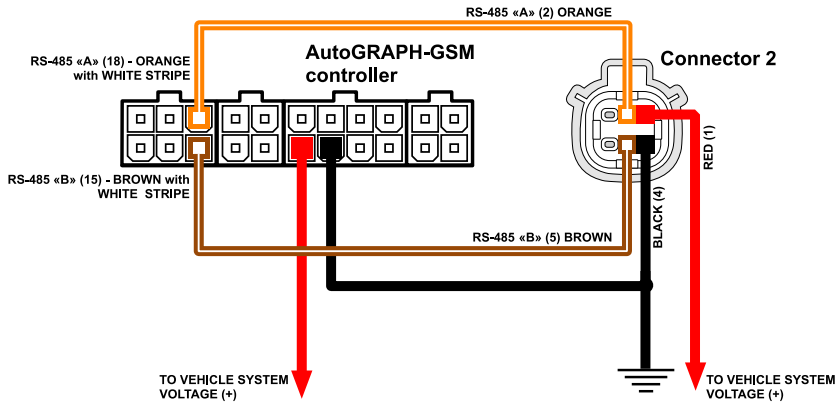

Be careful not to cross the "A" and "B" wires, otherwise the sensor may operate incorrectly.



All connections should be performed when the sensor and all external devices to be connected to the RS-485 bus are disconnected from the power supply.

Frequency Output Connection

TKLS sensor is equipped with one frequency output, which is open-collector. The frequency of the output signal is proportional to the fuel level in the tank.

The output frequency range varies from 100Hz to 3000Hz.

Maximum load current should not exceed 200 mA.

The frequency output is intended to be connected to the digital input of the AutoGRAPH on-board vehicle tracking device, which can acquire the reading in frequency form. Before connecting to the TKLS, the input of the AutoGRAPH must be switched to Frequency Mode.



The sensor must be connected to one of the active low digital inputs of the AutoGRAPH (inputs 1-4).

Internal diagram of frequency output:

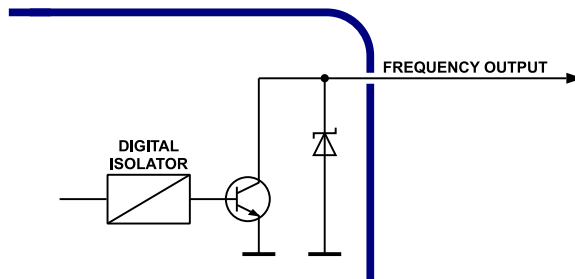

General Connection Diagram for Frequency Output:

The connection diagram of the sensor's frequency output to digital input of the AutoGRAPH-GSM on-board vehicle tracking controller is depicted in the figure below. This diagram is also true for another AutoGRAPH Series on-board vehicle tracking controllers.

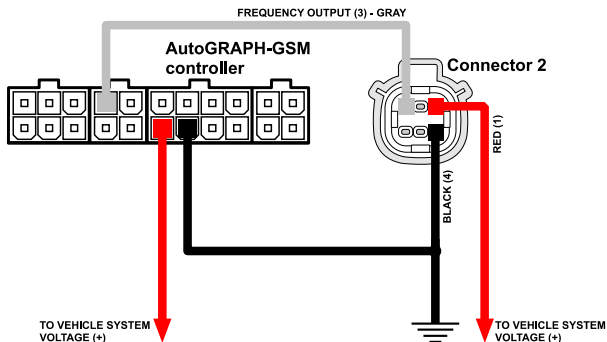

Error Codes

The TKLS sensor has an embedded self-diagnostic procedure that provides detection of errors during sensor operation.

When connected to the “AutoGRAPH-GSM” controller via RS-485 bus the TKLS sends error codes (if any) to the controller. The code will be recorded in the controller as a temperature record.

Error Code Description

Error Code	Error / failure description
-127	short circuit
-126	capacitance probe break
-125	frequency out of calibration range
-124	built-in accelerometer fault



The TKLS sensor transfers the error code via RS-485 only when it is connected to the “AutoGRAPH” Series onboard vehicle tracking controllers. When connecting to other external device, the error code won't be transferred.

Diagnostic operation can be performed using the “TKLSConf” configuration program. If an error has occurred, this will be shown in the program window.

Sensor Configuration

The TKLS can be set up in the following ways:

- using the «TKLSConf» Configuration Software;
- remotely via Bluetooth;
- remotely via RS-485;

To set up the sensor using the “TKLSConf” program it is necessary to connect the device to a PC or a laptop. For correct operation, the sensor drivers should be installed before connection. If the device drivers have not been installed, follow the steps in the “Installing the Drivers” section.

To connect the sensor to a PC, use the special adaptor and USB data cable supplied with the sensor (see fig.1).

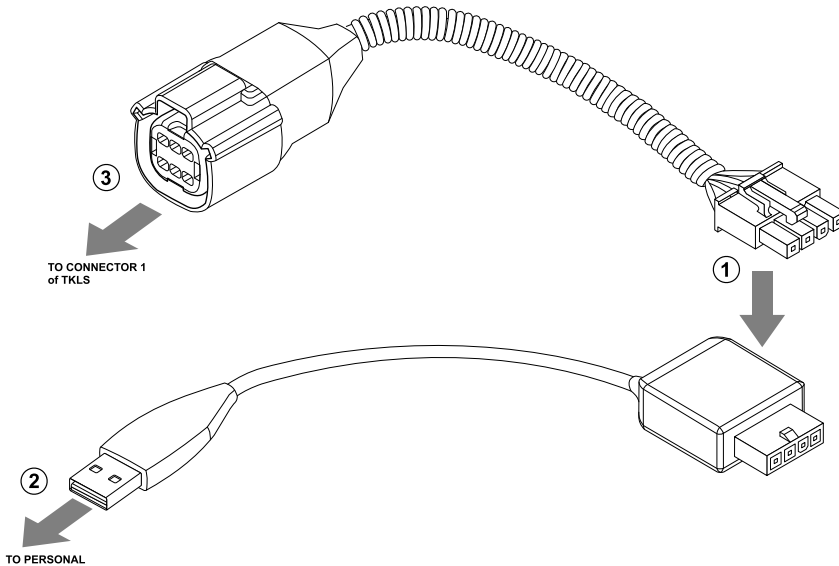

Fig.1 – Connection to a PC.

To connect the sensor to a PC follow these steps:

- turn off the sensor power supply;
- connect the 4-pin connector of the USB cable to the 4-pin connector of the adaptor (see fig.2, step 1);
- connect the USB cable to the PC (fig.2, step 2);
- connect the free end of the adaptor (Molex connector) to Connector 1 of the sensor (fig.2, step 3);
- if the sensor drivers were previously installed, the PC will automatically detect the connected device.



For more information on the “TKLSConf” Software see “TKLS Configuration Software” help file.

The “TKLSConf” Software provides configuration of the sensor via the RS-485 bus. The customer can specify the settings in the “TKLSConf” program and send them to the data server. These settings will be transferred to the “AutoGRAPH” onboard controller which is connected to the sensor and after that will be transferred to the sensor via the RS-485 bus.

The sensor supports remote configuration via Bluetooth using a mobile device. To do this, the Bluetooth option must be enabled in the sensor’s settings and an access password must be known by the customer.

Driver Installation

This section covers an installation procedure of the TKLS driver. For proper operation the AGUSB Driver must be installed before the sensor connection to a PC. This driver can be downloaded for free from the official website of TechnoKom. The AGUSB Driver is compatible with MS Windows 7, 8, Server 2003, Server 2008 (x86 и x64).

To install the driver:

Connect the sensor to a PC.

The system will automatically search for a new equipment.

If the Internet connection is available, the TKLS driver will be automatically downloaded from Windows Update server and installed. If the Internet connection is not available, continue with the procedure outlined below.

Download the archived drivers folder from the official website of TechnoKom and extract files to a temporary directory on a hard driver.

Launch the driver update wizard and select “Browse my computer for driver software” to search for the drivers manually.

Install the driver. When the drivers is installed the system will automatically identify connected device. The sensor is ready to operate with configuration and troubleshooting applications.

Modbus Register Mapping

The TKLS is capable of communication via the RS-485 serial bus in the Modbus/RTU protocol. The TKLS supports the Modbus function 03 – Read Holding Registers.

Address (HEX)	Description
0x00	TKLS address
0x01	RS-485 baud rate (high bit)
0x02	RS-485 baud rate (low bit)
0x03	Full calibration (high bit)
0x04	Full calibration (low bit)
0x05	Zero calibration (high bit)
0x06	Zero calibration (low bit)
0x07	Averaging time / weighting coefficient (%)
0x08	Temperature
0x09	Raw fuel level data (high bit)
0x0A	Raw fuel level data (low bit)
0x0B	Fuel level
0x0C	Serial number (high bit)
0x0D	Serial number (low bit)
0x0E	Averaging method
0x0F	Output frequency when tank is full
0x10	Output frequency when tank is empty
0x11	Raw fuel level data before temperature-compensation (high bit)
0x12	Raw fuel level data before temperature-compensation (low bit)
0x13	Averaged raw fuel level data (high bit)
0x14	Averaged raw fuel level data (low bit)
0x15	Error code (high bit)
0x16	Error code (low bit)
0x17	Number of input pulses (high bit)
0x18	Number of input pulses (low bit)
0x19	Roll angle
0x1A	Pitch angle



Reading Modbus Holding Registers is supported by the firmware of revision TKLS-1.32.

Appendix

APPENDIX 1: SAE-5 MOUNTING.

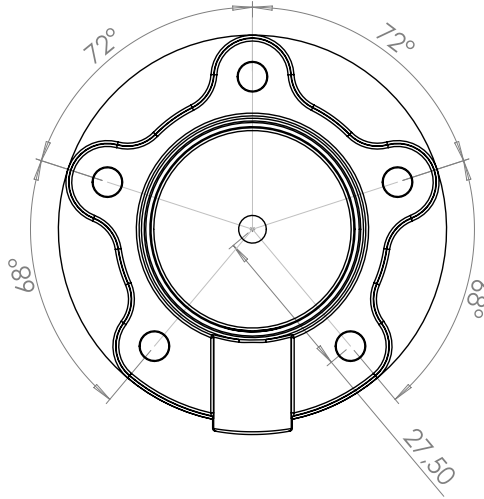

APPENDIX 2: BUILD-IN ACCELEROMETER AXES ORIENTATION.

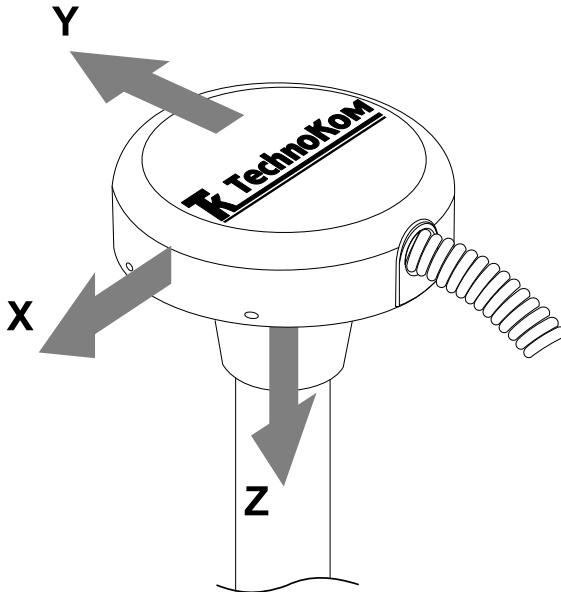



USER MANUAL

v.1.7

TechnoKom Ltd.

Copyright © Chelaybinsk, 2015. All Rights Reserved.

www.tk-chel.ru

mail@tk-chel.ru